

**INSTALLATION INSTRUCTIONS
FOR
CHEVROLET SILVERADO 1500 PICK UP 4 X 4 1984
AND
DODGE RAM 2500/3500 4 X 4 PICK-UP 1995 TO CURRENT
(ALSO OTHER FULL SIZE 4 X 4 PICK-UPS)**

PARTS NEEDED:

11-14-02

31-140	SAFE-T-PLUS unit (Silver)	AKS
Z-310K13	Mounting Hardware Kit consists of:	
	25-310	Anchor Bracket DM
	25-304	Anchor Bracket
	25-401	Tie Rod Bracket
	10-8-150	3/4-16 X 1-1/2" Bolt
	14-325 (4)	7/16-14 Top Lock Nut
	15-250 (4)	7/16 SAE Flat Washer
	14-800	3/4-16" Stover Lock Nut
	11-716-3504K (2)	7/16 X 3-1/2 X 4" U-Bolt
	12-516-1125K	5/16 X 1-1/8" U-Bolt Kit

Anchor Bracket 25-310 is mounted on the passenger (right) of the vehicle. Anchor Bracket 25-310 is mounted under the axle with the two 7/16 X 3-1/2 X 4" bolts provided. Angle bracket 25-304 is attached to Anchor Bracket 25-310 with 3/4 X 1-1/2" bolt and nut provided. (See Illustration #1)

Tie Rod Bracket 25-401 is attached to the large end of the SAFE-T-PLUS unit, which is attached to the tie rod with u-bolts provided (see sketch). **Leave bracket loose.** (See Illustration #1)

Thoroughly clean the section to tie rod before attaching bracket.

Step 2. Install unit to Anchor Bracket and Tie Rod Bracket using rubber-bushing kit provided (See Illustration #2.)

NOTE: All grommets are to be tightened until they bulge over the edge of the steel caps or until they are approximately 1/4" thick.

Step 3. Rotate Tie Rod Bracket around tie rod so that the small diameter end of the SAFE-T-PLUS unit is approximately 1/2" lower than the large end of unit.

When positioned, tighten the four (4) u-bolt nuts to 20-25 foot pounds of torque while maintaining an even amount of threads extending past each nut.

Step 4. Check to be sure installed unit clears all other parts of vehicle by turning steering wheel to both extremes right and left positions. If unit scrapes or binds at any point, review these instructions and make necessary corrections by rotating unit on the tie rod to obtain necessary clearance. You may also need to angle Anchor Bracket down slightly to ensure proper clearance.

Step 5. ROAD TEST & ADJUSTMENT PROCEDURES: To ensure proper alignment and

installation of the SAFE-T-PLUS unit, the vehicle should be road tested. Take along a socket wrench to fit the U-bolts on the tie rod. While driving on a straight stretch of road, vehicle should easily follow a straight course, if not, adjustment is necessary. To adjust, hold steering wheel in a straightforward position, stop vehicle, and set brakes. Loosen nuts on tie rod U-bolts and allow unit to self-center. (frequently this movement is not noticeable). Retighten nuts and test-drive again. Repeat this step if necessary until vehicle will hold a straight line. Note: Continue to hold the steering wheel in a straightforward position until the adjustment has been completed. Otherwise the wheels will return to the pulling position instead of the Straight-ahead position desired. If you need additional assistance, please call us toll-free at (800) 872-7233.

Illustration #2

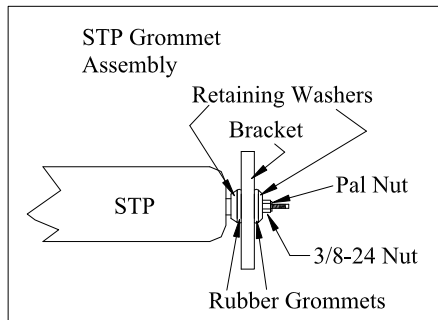

Installation Instructions For Z-310K13

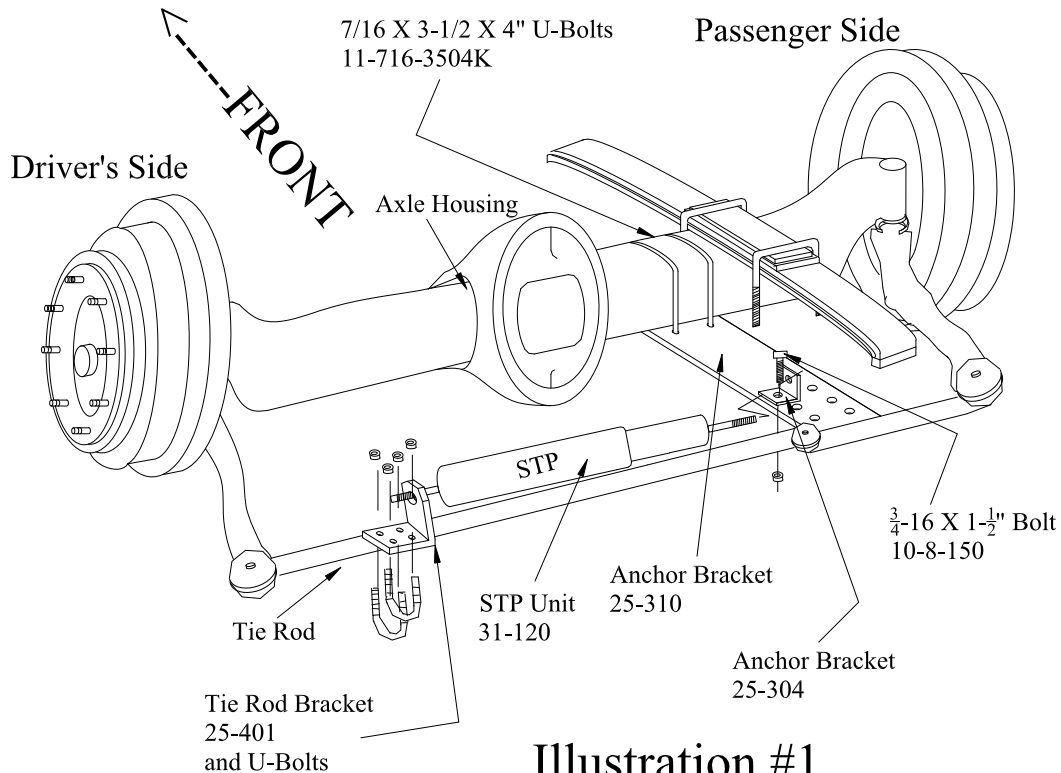

Illustration #1