

# SAFE T PLUS

## Steering Control

### INSTALLATION INSTRUCTIONS

#### For JD-800K1

Parts Needed:

41-140 or	SAFE T PLUS (Red) unit (Dodge & Road master)
41-230	SAFE T PLUS (Blue) unit (Oshkosh, Spartan, Freightliner)
JD-800K1	Mounting Hardware Kit consists of:
55-126-5	Anchor Bracket
55-206	Tie Rod Bracket
12-38-1250K	3/8 X 1-1/4" U-Bolt Kit

Thoroughly clean the section to tie rod before attaching bracket.

Anchor Bracket 55-126-5. Remove nuts from front axle spring rear U-Bolt. Install bracket. Replace and tighten nuts securely. **Bracket must clear below tie rod by at least 1/4".**

Tie Rod Bracket 55-206. Using U-Bolt and nuts provided, install Tie Rod Bracket on opposite end of tie rod on bottom with two (2) 3/4" mounting holes extending from the side of the tie rod to which unit will be mounted. Leave bracket slightly loose on the tie rod for final positioning later.

- Step ①. Set front wheels of vehicle to a straight-ahead position. **This is important.** Later adjustment of the Tie Rod Bracket may be avoided if front wheels are set perfectly straight.
- Step ②. After selecting best installation position, install Anchor Bracket end of unit first. Align holes and insert one of the 3/4" bolts provided, using a flat washer on the opposite side of the unit mounting eye from bracket.
- Step ③. Install 3/4" locknut to mounting bolt and tighten with a wrench to **80-90 foot pounds** of torque.
- Step ④. Attach the unit to tie rod by sliding Tie Rod Bracket to align the nearest 3/4" hole in bracket with unit mounting eye. Insert 3/4" bolt provided through aligned holes. Using a flat washer on opposite side of unit mounting eye from bracket, fasten locknut and tighten with a wrench enough to allow the unit eyelet to easily rotate around mounting hole.

- Step 5. Rotate Tie Rod Bracket around tie rod so that the small diameter end of the SAFE T PLUS unit is approximately 1/2" lower than the large end of the unit. When positioned, tighten the four (4) U-Bolt nuts to **25-35 foot pounds** of torque while maintaining an even amount of threads extending past each nut.
- Step 6. Tighten 3/4" locknut to **80-90 foot pounds** of torque.
- Step 7. Check to be sure installed unit clears all other parts of vehicle by turning steering wheel to both extremes right and left positions. If unit scrapes or binds at any point, review these instructions and make necessary corrections by rotating unit on the tie rod to obtain necessary clearance.
- Step 8. **ROAD TEST & ADJUSTMENT PROCEDURES** – See attached documents.

After your first road trip with Safe T Plus Steering Control installed, please let us know how Safe T Plus performed. We enjoy hearing from our clients. You may contact us at [support@safe-t-plus.com](mailto:support@safe-t-plus.com) or (800) 872-7233.

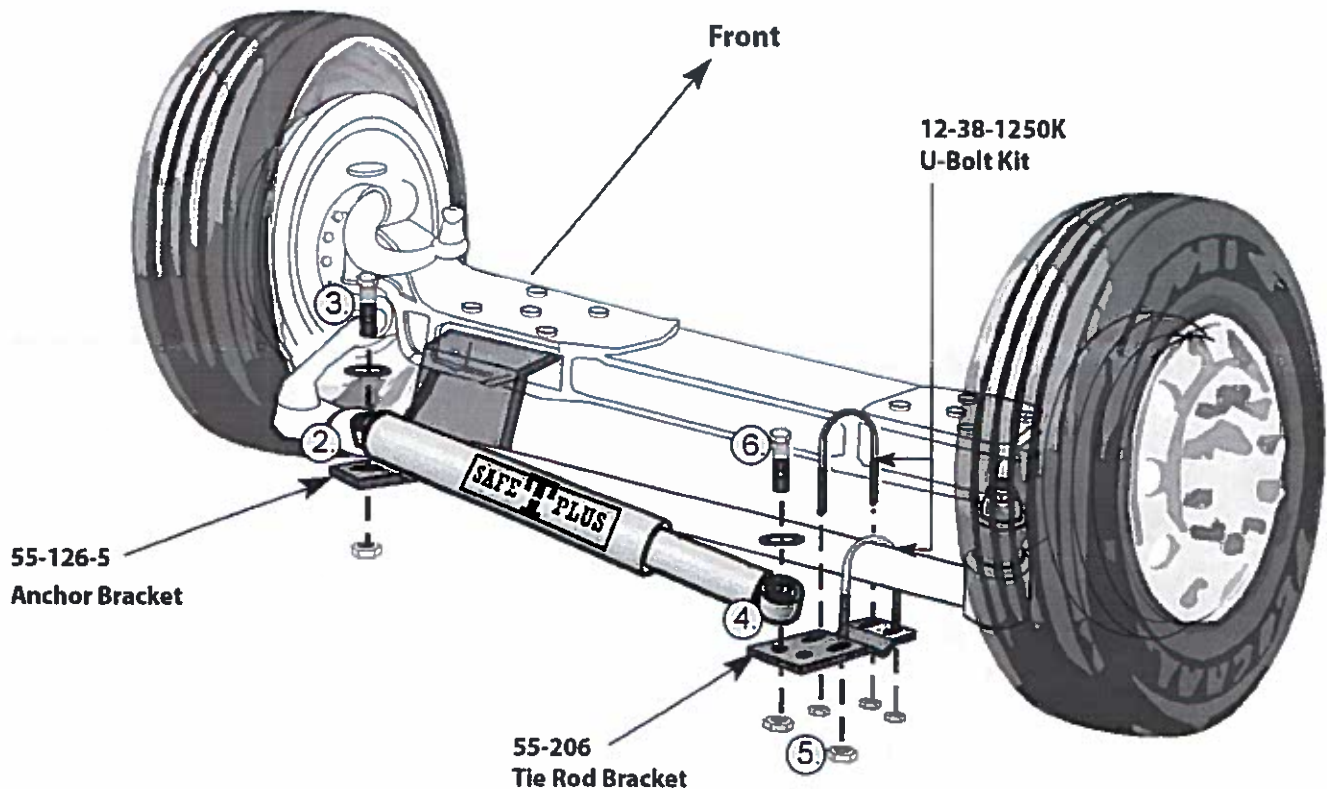



## Road Test & Centering/Adjustment Procedures

To ensure proper alignment and installation of the SAFE-T-PLUS unit, the vehicle should be road tested. Take along a 9/16" deep well socket wrench to fit the U-bolts on the tie rod. While driving on a straight stretch of road, vehicle should easily follow a straight course, if not, adjustment is necessary.

To adjust Safe-T-Plus Steering Control follow the below instructions:

1. After installation, test drive the vehicle
2. Try to test with the most perfect conditions: straight road, no crown, limited wind (if possible), freeways seem to work best or large parking lots.
3. Hold steering wheel in a straightforward position to determine if the vehicle is tracking straight or pulling to the left or the right.
4. Stop vehicle, and set brakes.
5. Take note of where the steering wheel *must be held* to track straight down the road, and mark it accordingly. Pull in somewhere, and with the motor, steering pumps, all running. Have someone hold that steering wheel firmly in exactly the proper position.\*
6. Underneath the vehicle, slightly loosen nuts on tie rod U-bolts and allow unit to self-center. tap the Safe-T-Plus unit a few times with your fist, or a rubber mallet, and let the internal spring push / pull the tie rod bracket into a neutral position. (Frequently this slight movement is not noticeable)
7. At this point, take a moment to square-up the U-bolts as they lay up and across the tie rod. If you've left them askew, they may pull the bracket out of position as they tighten.
8. Retighten the U-bolt nuts (only 25-30lbs. of torque)
9. Now test drive again.
10. Repeat this step if necessary until vehicle will hold a straight line\*\*

### Note:

\*Be mindful that if you are holding 2 to 3 inches of steering wheel against the spring to track straight, it's only 1/16 to 1/8 of an inch down below on the tie rod bracket.

\*\*Repeat if necessary, until you're satisfied. Once completed you should be able to achieve holding your lane position for a 1/2 mile or so at freeway speeds, with hand gently resting on the steering wheel without correcting.

## Extra Detail on Final Adjustments (Tips)

- Using tape, you can stick a ruler or pencil to the dash to act like a centering indicator for more accuracy.
- Another trick is marking the left and right limits of any inherent slop in the center of the steering wheel operation. At the shop, line up the center marks, and do the install.
- Be patient, be precise when moving the tie rod bracket, as just a 1/16 of an inch will make the difference in drifting off half a lane in 100 yards or less.

When making very small adjustments, (1 ½ inches of steering wheel displacement or less) it may be necessary to hold the steering wheel in the direction of correction just a little beyond the required (¼ to ½ inch more) in order to "load up" the internal spring just a little and let the unit help with the relocation of the tie rod bracket. There really isn't any other way to move the tie rod bracket without having some assistance holding the steering wheel while adjustments are being made down below.

If overshooting the desired results, mark a line a set distance from the tie rod bracket so that they can measure in what direction, and how far each adjustment was made.

A "how-to" properly center/adjust Safe-T-Plus Steering Control video is available on our website to help guide you through the adjustment procedures. Feel free to check out video at [www.safe-t-plus.com](http://www.safe-t-plus.com) (bottom right).



If you need additional assistance, please call us toll-free (800) 872-7233 or email us at [support@safe-t-plus.com](mailto:support@safe-t-plus.com) and technical support will be happy to assist.