

**SAFE-T-PLUS INSTALLATIONS
BASIC TRUCK APPLICATION – I BEAM FRONT AXLES
GENERAL INSTRUCTIONS**

1. The Safe-T-Plus Unit is installed behind the front axle, either (1) between the tie rod and front axle (preferred, see sketch # 1, or #2 directly behind the tie rod (acceptable, see sketch #2).
The proper position is determined by selecting the location having adequate clearance for the unit to operate throughout both extremes of the steering radius without touching other parts of the vehicle.
2. The Safe-T-Plus Unit is a positive centering device. It is shipped from the factory in a centered condition and should be installed as is without any extension or compression of the unit at installation.
3. Parts used in installation and included in this package are:

1 - SAFE-T-PLUS Unit	2 - 3/4" Flat Washers
2 - 3-1/2" X 3/4" Mounting Bolts	2 - 3/4" Lock nuts
4. Other parts needed for installation include:

1 - Anchor Bracket, selected based on spring U-bolt size and tie rod location.
1 - Tie Rod Bracket, selected based on tie rod diameter
1 - Tie Rod Mounting Kit, consisting of U-bolts and 4, 3/8" lock nuts.

 - Some applications allow the unit or the anchor bracket to be flipped around for proper installation or clearance issues.

STANDARD INSTALLATION INSTRUCTIONS

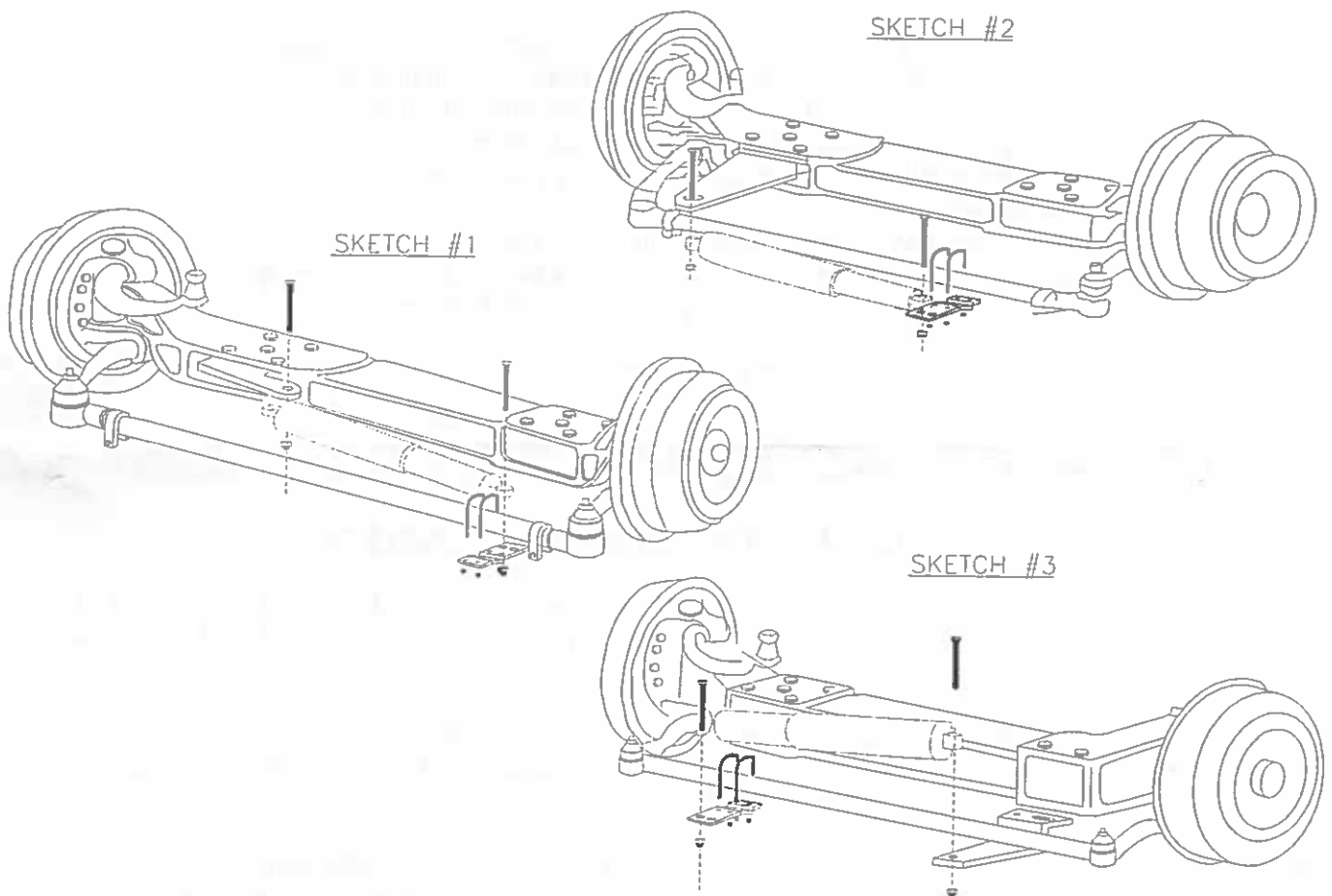

**UNITED SAFETY APPARATUS, INC. SAFE-T-PLUS STEERING CONTROL
STANDARD INSTALLATION PROCEDURE (with lock nuts)**

1. Anchor Bracket. Remove nuts from front axle spring rear U-bolt, install bracket, replace and tighten nuts securely, (Bracket must clear above or below tie rod by at least 1/2" if rear mount).
2. Using U-bolts and nuts provided, install Tie Rod Bracket on opposite end of tie rod with 3/4" mounting holes extending from the side of tie rod to which unit will be mounted. Leave bracket slightly loose on tie rod for final positioning later. Thoroughly clean this section of tie rod before attaching bracket.
3. Set front wheels of vehicle to a straight-ahead position. This is important. Later adjustment of the Tie Rod Bracket may be avoided if front wheels are set perfectly straight.
4. Select the best unit to bracket installation position based on the following procedure:
 - (A) Unit should be installed to provide maximum protection by front axle.
 - (B) Small diameter end of unit should be 1/2" to 1" lower than large end of unit when installation is complete.
 - (C) Unit may be attached either above or below both Anchor and/or Tie Rod Bracket.
 - (D) It is preferable to install unit with large diameter end attached to Anchor Bracket; however, it may be installed in the opposite direction to obtain desired angle.
5.
 - (A) After selecting best installation position install Anchor Bracket end of unit first. Align holes and insert one of the 3/4" bolts provided, using a large flat washer on the opposite side of unit mounting eye from bracket.
 - (B) Install 3/4" lock nut to mounting bolt and tighten with a wrench to 80-92 pounds of torque.
6.
 - (A) Next attach unit to tie rod by sliding Tie Rod Bracket to align the nearest 3/4" hole in bracket with unit mounting eye. Drop 3/4" bolt provided through aligned holes. Using a flat washer on opposite side of unit mounting eye from bracket, fasten a locknut and tighten with a wrench just enough to allow the unit eyelet to still easily rotate around the mounting bolt.
 - (B) Adjust the Tie Rod Bracket by rotating around tie rod to the point necessary to bring small diameter end of unit to a point 1/2" to 1" lower than large end of unit. When positioned tighten the four U-bolt nuts to 20/30 pounds of torque.
 - (C) Tighten 3/4-16 locknut to 80-90 pounds of torque.
7. Check to be sure installed unit clears all other parts of vehicle by turning steering wheel to both ~~extreme positions~~. If unit scrapes or binds at any point, review these instructions and make necessary corrections.

ROAD TEST & ADJUSTMENT PROCEDURES

To ensure proper alignment and installation of the SAFE-T-PLUS unit, the vehicle should be road tested. Take along a socket wrench to fit the U-bolts on the tie rod. While driving on a straight stretch of road, vehicle should easily follow a straight course, if not, adjustment is necessary.

To adjust, hold steering wheel in a straightforward position, stop vehicle, and set brakes. Loosen nuts on tie rod U-bolts and allow unit to self-center. (Frequently this movement is not noticeable). Retighten nuts and test drive again. Repeat this step if necessary until vehicle will hold a straight line.

Note: Continue to hold the steering wheel in a straightforward position until the adjustment has been completed. Get assistance if necessary, otherwise the wheels will return to the pulling position instead of the straight-ahead position desired.

If you need additional assistance, please call us toll-free (800) 872-7233.