

Slipper Spring Kit (part numbers 2560, 2570 and 2580)

Item	Qty	Part number	Description
1	...8	...350054-50	...3/8-16 x 1" grade 8 self-tapping screw
2	...4	...350084-00	...7/16-14 x 4" grade 5 bolt
3	...4	...350157-00	...5/8-11 x 4 1/4" grade 8 bolt
4	...2	...350216-60	...9/16-12 x 4 1/2" grade 8 bolt
5	...4	...350257-00	...7/16-14 grade 5 nylon insert lock nut
6	...2	...350261-25	...9/16-12 grade 8 nylon insert lock nut
7	...4	...350263-20	...5/8-11 grade 8 nylon insert lock nut
8	...8	...350308-50	...wedge washer
9	...4	...350347-20	...9/16" grade 8 flat washer
10	...2	...A-005848	...1" O.D. x 0.640" I.D. x 2" spacer
11	...4	...A-005765	...1" O.D. x 0.640" I.D. x 2.625" roller
12	...4	...A-005843	...1" O.D. x 0.500" ID. x 2.690" spacer
13	...2	...B-003318	...slipper spring box
14	...4	...D-000104	...6K leaf spring - 2560
	4	...D-000105	...7K leaf spring - 2570
	4	...D-000106	...8K leaf spring - 2580

Shock system kit (part numbers 2450 and 2460)

Item	Qty	Part number	Description
15	...4	...204000-00	...shock absorber
16	...8	...350095-00	...1/2-13 x 1 1/2" grade 5 bolt
17	...8	...350259-00	...1/2-13 grade 5 nylon insert lock nut
18	...16	...355720-00	...M12 flat washer
19	...8	...357211-100	...M12 x 1.75 x 100mm bolt - class 8.8
20	...8	...357212-50	...M12 x 1.75 nylon insert lock nut - class 8.8
21	...4	...A-005494	...shock extension plate
22	...8	...A-005764	...1/2" spacer
23	...2	...C-003264	...tie plate for 2-3/8" axle - 2450
	2	...C-003169	...tie plate for 3" axle - 2460
24	...2	...C-003265	...tie plate for 2-3/8" axle - 2450
	2	...C-003170	...tie plate for 3" axle - 2460

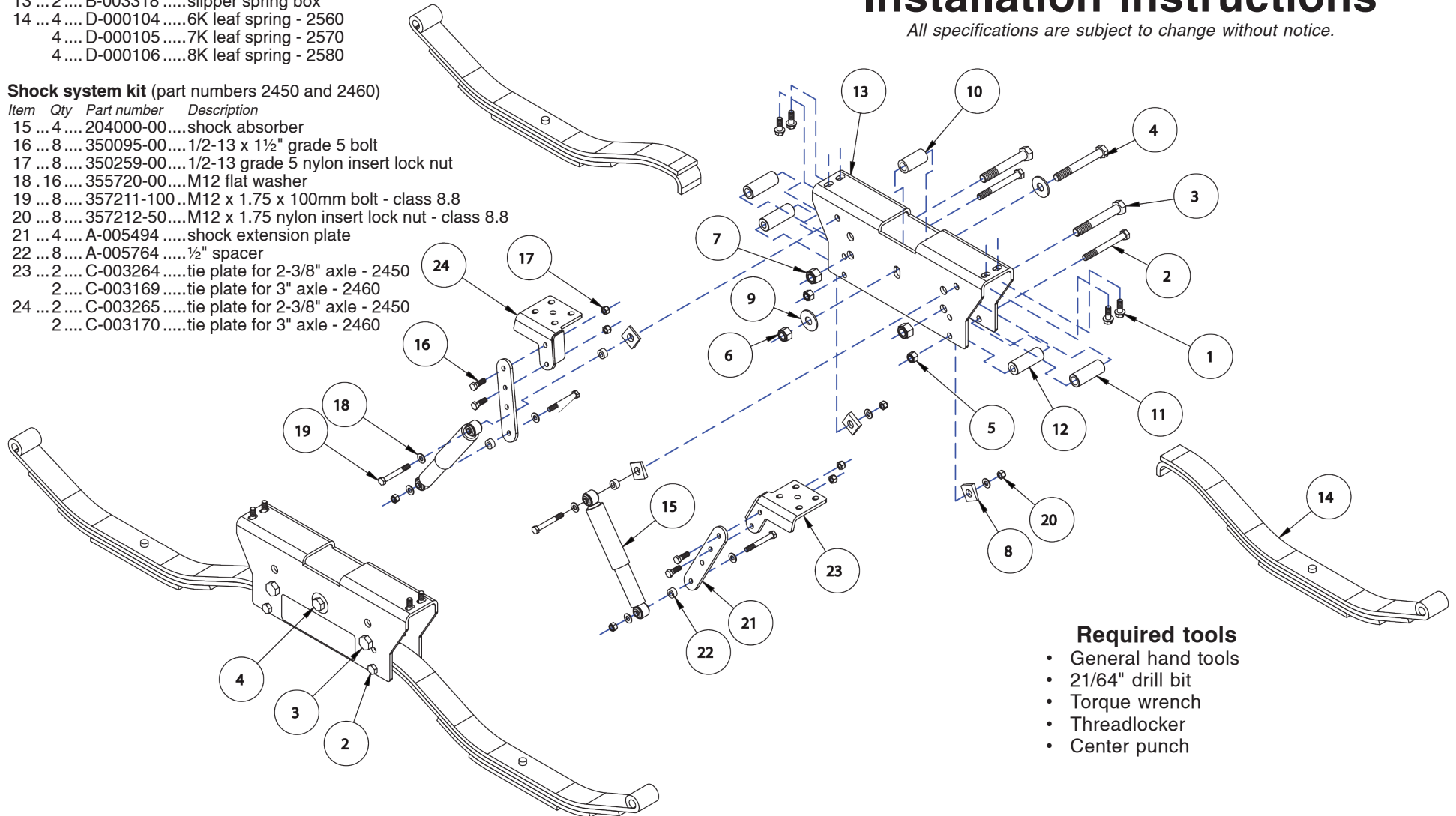

Comfort Ride

Slipper leaf spring system (part numbers 2560, 2570 and 2580)
and shock absorber system (part numbers 2450, 2460 and 2470)

Installation Instructions

All specifications are subject to change without notice.

Required tools

- General hand tools
- 21/64" drill bit
- Torque wrench
- Threadlocker
- Center punch

Safety Definitions

These instructions contain information that is very important to know and understand. This information is provided for **safety** and to **prevent equipment problems**. To help recognize this information, observe the following symbols:

WARNING

WARNING indicates a potentially hazardous situation which, if not avoided, could result in property damage, serious personal injury or even death.

CAUTION

CAUTION indicates a potentially hazardous situation which, if not avoided, may result in property damage, or minor or moderate personal injury.

CAUTION

CAUTION used without the safety alert symbol indicates a potentially hazardous situation which, if not avoided, may result in property damage.

NOTE

Refers to important information and is placed in italic type. It is recommended that you take special notice of these items.



ROADMASTER, Inc. • 6110 N.E. 127th Ave.
Vancouver, WA 98682 • 800-669-9690
Fax 360-735-9300 • roadmasterinc.com
855861-02 03.18

Before you begin the installation...

ATTENTION

The leaf springs are to be used only in conjunction with a Comfort Ride shock absorber system. Don't install the leaf springs by themselves.

- Check that you have the correct kit. Kit number 2560 is for axles up to and including 6,000-pound capacity; kit number 2570 is for 7,000-pound capacity axles; and kit number 2580 is for 8,000-pound capacity axles. If your trailer's axles fall between these weight capacities, use the kit with the closest capacity.
- Ensure that the U-bolts attaching the trailer's leaf springs to the axles have at least $\frac{1}{2}$ " of thread showing beyond the nut (Figure 1).
- Check for any under-vehicle obstructions in and around the trailer's suspension (such as plumbing, wiring or other trailer components) that may prevent the installation of the product. It may be necessary to modify or relocate components in order to install this product.



General warnings and cautions

WARNING

Read all instructions before installing this product. Failure to understand how to install this product could result in property damage, personal injury or even death.



Note: If you're a professional installer, please give these instructions to the customer once the kit is installed.

Note: For ease of installation, the shock absorbers are shipped with restraining bands to hold them at a specific length. Don't remove the restraining bands until instructed to do so.

Installation

1. Lift the trailer by the frame so that the suspension hangs. Ensure the trailer is level at all four corners.

CAUTION

Don't lift the trailer by the axles. Doing so could adversely affect the alignment of the axles or result in a bent or otherwise damaged axle.

2. Remove the wheels and tires.
3. Support all axles at both ends with stands. Position the stands at the ends of each axle, not in the middle.
4. Detaching the axles from the springs:
 - a. Test to see if the axle U-bolts can be removed. If they cannot, soak them in a quality penetrating oil.
 - b. Ensure that the trailer brake wiring will not be damaged when the axles are detached from the springs.
 - c. Detach the axles from the springs by removing the axle U-bolts and tie plates (Figure 2); keep the hardware for reinstallation.
5. Removing the three spring hanger bolts (Figure 3):

continued on next page

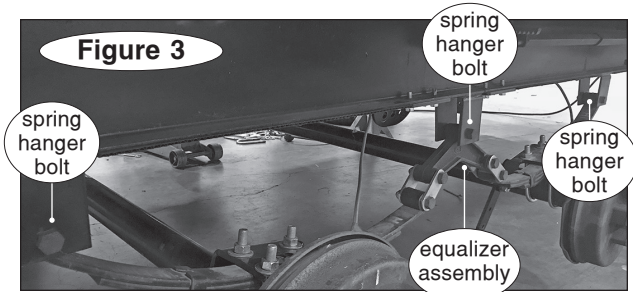
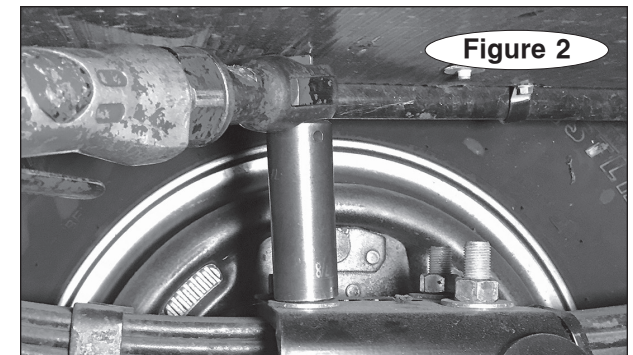

continued from preceding page

CAUTION

Do not attempt to turn the spring hanger bolt heads. On many trailers these are splined bolts. If you turn the bolt head the bolt may break and/or the spring hanger flanges may be damaged.

Follow the instructions below to remove the bolts.

- a. Remove the spring hanger nuts from the bolts.
- b. Use a C-clamp or similar device to secure the spring hanger flanges to each other so they don't bend when the bolt is driven out.
- c. Position a center punch or similar device on the end of the bolt and hammer the center punch to drive the bolt out.

Note: You will be reusing these bolts. For that reason, don't hammer directly on the end of the bolt, or you will deform the threads.

- d. Repeat for the other side of the trailer.
6. Remove the leaf springs and the equalizer assembly.
7. Ensure that the center equalizer hanger flanges are straight and vertical. If necessary, bend them (Figure 4).

8. Installing the slipper spring box:

- a. Insert one of the included 2" pipe spacers between the flanges of the center equalizer hanger (Figure 5).
- b. With the stick-

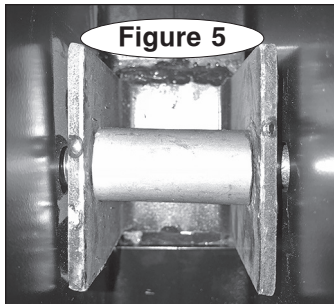

er (Figure 6) facing the outside of the trailer, slide the slipper spring box up and over the equalizer hanger bracket. Align the central slotted hole on the slipper spring box to the hole in the equalizer hanger bracket.

c. The slipper spring box must sit flush against the bottom of the frame. Check for obstructions such as underbelly material, plumbing, etc. and remove or reposition them.

Note: If it's necessary to trim underbelly material, use a utility knife and apply repair tape or other sealing product approved by the trailer manufacturer to seal the cut.

d. Position a 9/16" flat washer over one of the included 9/16" x 4 1/2" bolts and insert it through the central hole in the slipper spring box and the 2" pipe spacer. On the opposite side of the slipper spring box, finish with another 9/16" flat washer and 9/16" nylock nut. Leave loose at this time.

Figure 7 shows the slipper spring box installed. 9. Align the slipper spring box so that it is in line

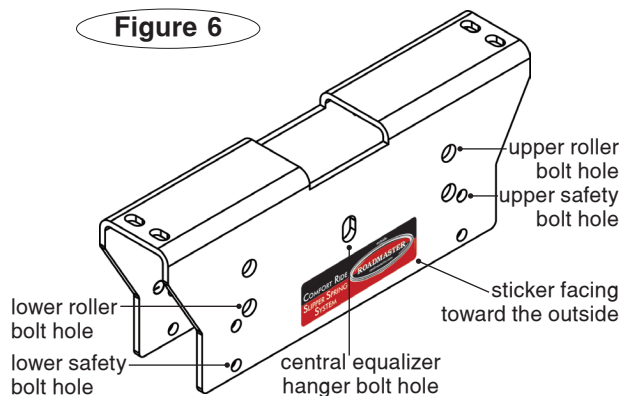

with the trailer's frame rail and centered underneath the frame rail.

Using the pre-existing holes in the top of the slipper spring box as templates, mark and drill four 21/64" diameter holes through the frame rail (Figure 8).

Note: to hold the slipper box in place, use a small self-drilling screw for the first hole, rather than a drill bit. When the other three holes are drilled, replace the screw with one of the included 3/8" self-tapping screws (step 10, below).

10. Use four of the included 3/8" self-tapping screws to attach the slipper spring box to the frame using the holes you just drilled. Use threadlocker on the screws; tighten to 40 lb-ft.
11. Repeat steps 6 through 10 for the other side of the trailer.
12. Installing the new slipper springs (Refer to Figure 6 for the bolt locations in steps 12 and 13.):

a. Hold the slipper end of the spring inside the slipper

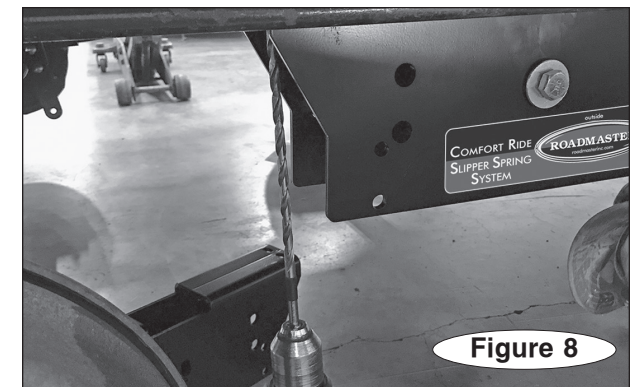

continued on next page

continued from preceding page

spring box. This will ensure proper orientation of both ends of the spring.

b. Insert the eyelet end of the spring between the flanges of the spring hanger, and reinstall the bolt you removed in step 5 (Figure 9). Drive the bolt home using a hammer to fully re-engage the splines.

c. Reinstall the nut on the spring hanger bolt and tighten to the trailer manufacturer's specifications. (The most common axle manufacturers' torque specifications are provided at the end of these instructions.)

Ensure that the spring can still pivot freely inside the hanger.

d. Repeat for all other springs on the trailer.

Note: The slipper ends of each spring are always inside the slipper spring box; the spring eyelets don't go inside the slipper spring box.

13. Installing the safety bolts:

a. Pivot the slipper spring up until it's inside the slipper spring box. Move the slipper end of the spring until both ends of the spring are approximately level with each other.

b. Insert a 7/16" bolt through whichever 7/16" hole in the slipper spring box is directly underneath the spring when held level, through a 2-11/16" pipe spacer and then through the other side of the slipper spring box.

The slipper spring should now be resting on the pipe spacer (Figure 10).

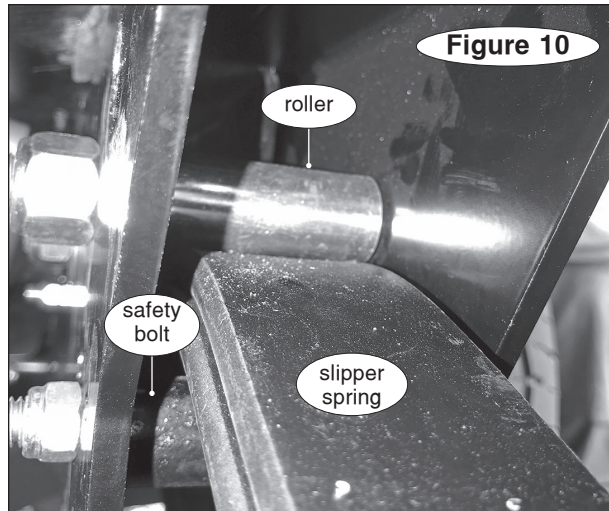

Finish with a 7/16" nylock nut and torque to 40 lb-ft.

Torque the central 9/16" bolt and nut you installed in step 8d to 50 lb-ft.

c. Repeat for all other springs on the trailer.

14. Installing the slipper spring rollers:

a. If you used the upper safety bolt hole, use the upper 5/8" hole for the roller bolt (Figure 11). If you used the lower safety bolt hole, use the lower 5/8" hole for the roller bolt.

Note: The roller should be positioned above the end of the leaf spring, inside the slipper box. The spring will contact the roller once the suspension is loaded.

b. Position the roller inside the slipper spring box. Insert a 5/8" x 4 1/4" bolt through the roller bolt hole, the roller, and then through the other side. Finish with a 5/8" nylock nut.

Torque to 58 lb-ft.

Ensure that the roller still moves freely.

c. Install the remaining three rollers.

15. Installing the new tie plates and shock absorber brackets:

a. Install the supplied tie plate in place of the original tie plate.

b. Position the tie plate so that the locating pin on the leaf spring engages the center hole in the tie plate. Ensure that the shock absorber mounting flange faces toward the center of the trailer and is positioned between the axles.

c. Reinstall the axle attachment U-bolts and nuts (Figure 2). Ensure that the springs are centered on the

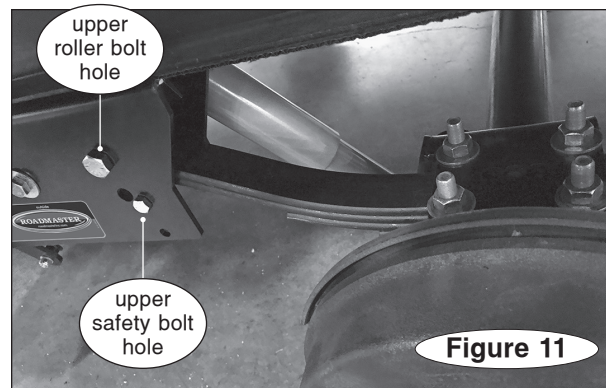

tie plate. Torque them using the axle manufacturer's specifications. (The most common axle manufacturers' torque specifications are provided at the end of these instructions.)

d. Repeat this process for each remaining pair of U-bolts.

16. Reinstall the wheels and tires, remove all jack stands and lower the trailer so the suspension is fully loaded.

CAUTION

Ensure that the suspension is fully loaded, i.e., bearing the weight of the trailer, before installing the shock absorbers. Otherwise, the shock absorbers will be at the wrong length once installed. The shock absorbers, as well as the trailer, may be damaged. Other collateral, non-warranty damage may also occur.

17. Installing the shock absorbers to the slipper spring boxes (Figure 12):

a. Position a 12mm flat washer on one of the included 12mm x 1.75 x 100mm bolts. Bolt through the top of the shock absorber, spacer, wedge washer and the slipper spring box.

Note: The wider portion of the shock absorber body is the top.

b. Finish with another wedge washer, 12mm flat washer and 12mm nylock nut.

c. Tighten the 12mm bolt and nut just enough so that the wedge washers will stay in place when you rotate

continued on next page

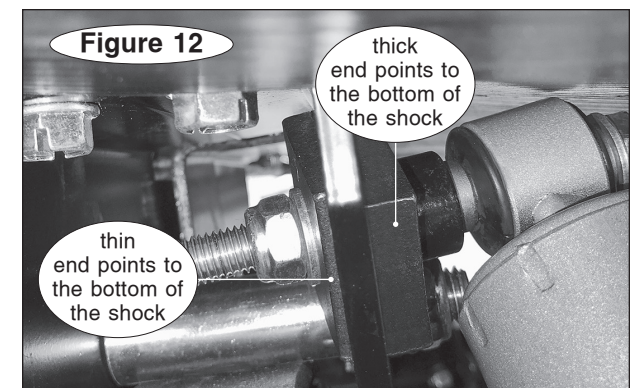

continued from preceding page

them. (The wedge washers will be rotated, and the shock mounting bolts torqued, in a later step.)

d. Repeat for the remaining shock absorbers.

18. Installing the shock absorbers to the axles:

a. The purpose of the restraining bands on the shock absorbers is to hold them at a fixed length. This length will dictate where the bottom of the shock absorbers will be fastened.

Note: If the restraining bands are damaged or cut, restrain the shock absorbers at a 14½" length, hole-center to hole-center.

CAUTION

The shock absorbers must be restrained at a 14½" length, as described above, in order to position the frame brackets correctly. Otherwise the shock absorbers will break. Other consequential, non-warranty damage may also occur.

While holding the bottom of a shock absorber, determine which of the installation options below places the bottom of the shock absorber closest to a mounting hole. (Figure 13):

i. Lowest position (Figure 13A): tighten the ½" x 1½" bolts holding the shock extension plate to the tie plate to 57 lb-ft.

ii. Middle position (Figure 13B): tighten the ½" x 1½" bolts holding the shock extension plate to the tie plate to 57 lb-ft.

iii. Highest position (Figure 13C): attach the shock

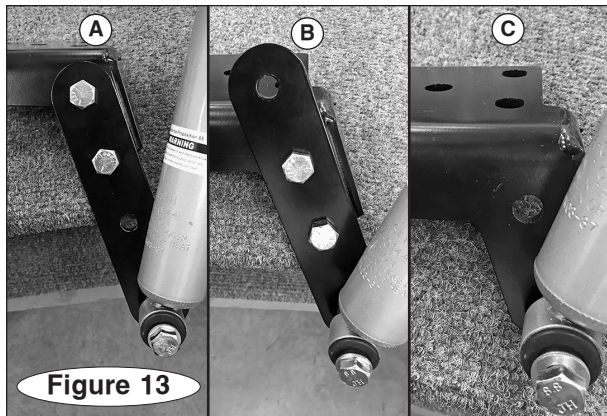

absorber to whichever mounting hole on the tie plate is more appropriate as described below.

iv. Alternative position: attach the shock absorber extension plate in either of the two positions outlined in (i) and (ii) above. Then use the hole in the bottom of the shock absorber as a template to drill a new ½" hole in the shock extension plate to mount the bottom of the shock absorber as described below.

CAUTION

Make sure the shock absorber extension plate doesn't extend below the level of the wheel rim. If it does, the plate or the shock absorber could be damaged in the event of a flat tire. Other consequential, non-warranty damage may also occur.

b. Position a 12mm washer on one of the included 12mm x 1.75 x 100mm bolts. Bolt through the bottom of the shock absorber, a spacer and whatever hole you chose. Finish with another 12mm washer and 12mm nylock nut. Leave loose at this time.

c. Repeat for the remaining shock absorbers.

d. On each top shock absorber mounting bolt, position the wedge washers (Figure 12) as follows:

i. The thick end of the wedge washer on the outside of the slipper box points toward the bottom of the shock absorber.

ii. The thin end of the wedge washer on the inside of the slipper box points toward the bottom of the shock absorber.

CAUTION

If the wedge washers aren't positioned as described above, the shock absorbers may be damaged. Other collateral, non-warranty damage may also occur.

e. Tighten all shock absorber mounting bolts to 55 lb-ft.

Remove the restraining bands from the shock absorbers.

Re-check the torque of all fasteners.

Note: All fasteners should be checked for correct tightness per the axle manufacturer's schedule or every 6,000 miles of towing, whichever comes first.

f. Figure 14 shows the complete system installed.

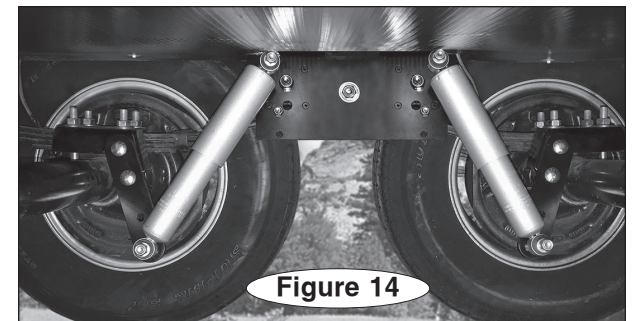

Torque values for trailer axles

Roadmaster has provided the torque charts furnished by the manufacturers of the most common axles in production. While these charts were correct at the time of publication, specifications may change without notice.

Dexter Axles

<i>Item</i>	<i>Torque Range (lb-ft)</i>
3/8" U-bolt	30-50
7/16" U-bolt.....	45-70
1/2" U-bolt with hex nut	45-70
1/2" U-bolt with flange nut	70-80
9/16" U-bolt	65-95
5/8" U-bolt	100-120
Non-shoulder type bolt.....	Snug fit only. Parts must rotate freely. Locking nuts or cotter pins are provided to retain
with 9/16" threads:	the nut/bolt assembly.
Shackle bolt	
Spring-eye bolt	
Equalizer bolt	
Shoulder type shackle bolt.....	30-50
with 7/16" threads	

Lippert Axles

2,000- to 8,000-pound capacity axles

<i>Bolt Type</i>	<i>Torque Specification (lb-ft)</i>
U-bolts (2,000 lb axle)	35
U-bolts (3,500 lb axle with 1/2" U-bolts).....	50
U-bolts (5,200 lb axle)	65
U-bolts (6,000-8,000 lb axles).....	90
Shackle bolts	30-50

8,000 to 12,000-pound capacity axles

<i>Bolt Type</i>	<i>Torque Specification (lb-ft)</i>
U-bolts (8,000 lb axle, 9/16" U-bolts)	90
U-bolts (10,000 lb axle, 5/8" U-bolts)	95
U-bolts (12,000 lb axle, 5/8" U-bolts)	115
9/16" shoulder bolts	35
9/16" non-shoulder bolts.....	Snug
10,000 lb and 12,000 lb spring-eye bolt	200
10,000 lb and 12,000 lb hanger/equalizer bolt	300
Keeper bolt	Snug

Rockwell American Axles

<i>Bolt Type</i>	<i>Torque (lb-ft)</i>
3/8" U-bolt	30-50
7/16" U-bolt.....	45-70
1/2" U-bolt.....	45-70
9/16" U-bolt	60-85
7/16" Shackle bolt.....	45-70
9/16" Shackle bolt	Snug