

# SumoSprings Rear

Ford E350/E450 (2001-Present)

Part #SSR-130-47/54

Installation Instructions

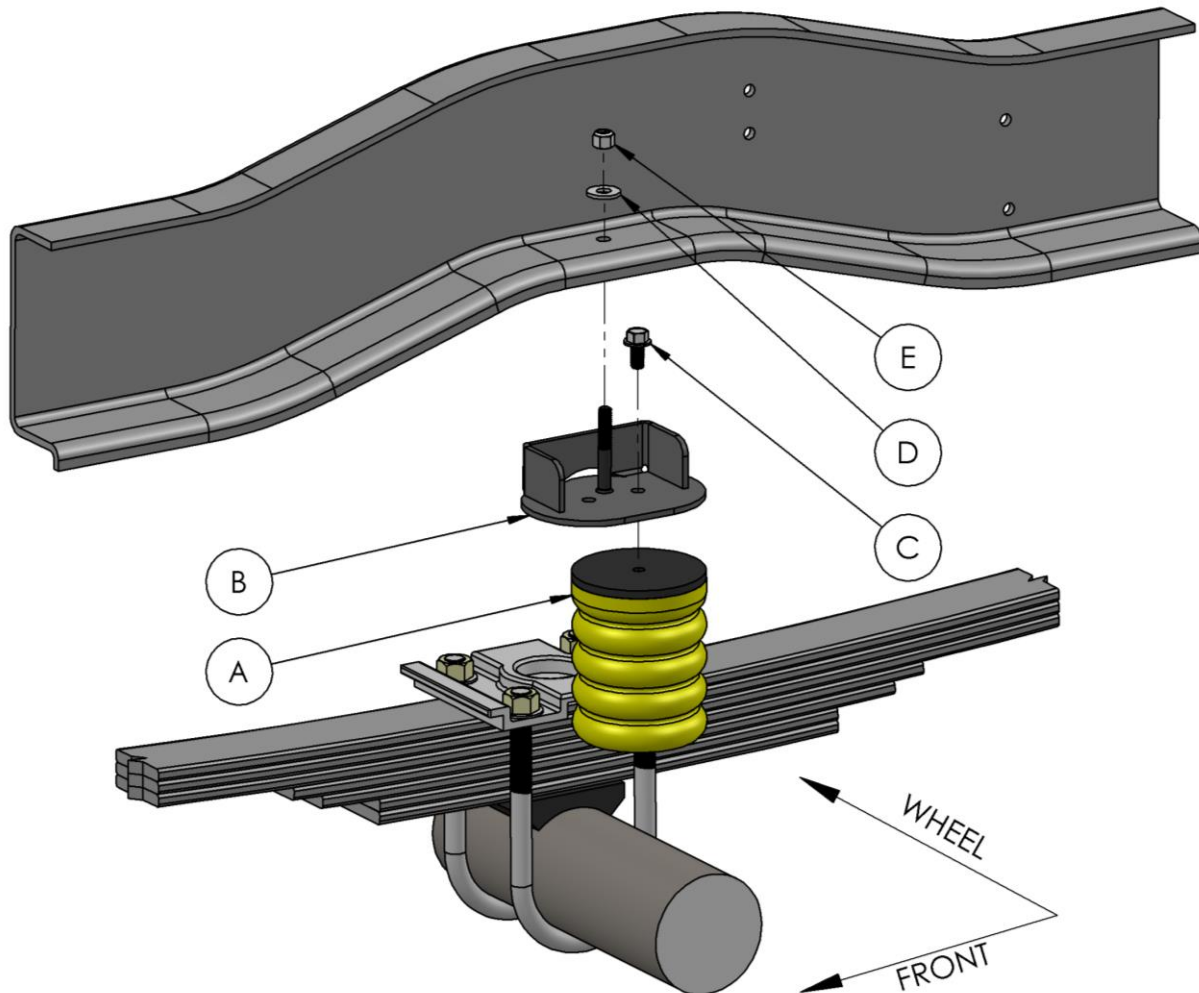

<u>Item</u>	<u>Part #</u>	<u>Description</u>	<u>Qty</u>
A	511421-38 511404-38	SumoSpring -47 Black SumoSpring -54 Yellow	2
B	512349	Mounting Bracket	2
C	512207	3/8-16x3/4 Flange Bolt	2
D	512227	3/8 Flat Washer	2
E	512323	3/8-16 Nylock Nut	2
Optional parts	512117	1 Inch Spacer	2
	512274	3/8-16x1.75 Flange Bolt	2

## **Installation Instructions**

- 1) Park vehicle on level hard surface. Place wheel blocks in front and behind the front wheels to prevent rolling. Observe all safety precautions and wear safety glasses.
- 2) Raise the rear of the vehicle allowing the axle to hang free and rest the frame on the safety jack stands rated for the weight of the vehicle. Removal of the rear wheels is optional.
- 3) Starting on the driver's side un-bolt and remove the factory jounce bumper from the underside of the frame and set aside.
- 4) Attach the mounting bracket (item B) to the frame by inserting the stud into the same hole from which the factory bump stop was removed. Position the bracket so that the open side is facing inboard as in the diagram.
- 5) Secure the bracket in place using the 3/8 nylock nut (Item E) and 3/8 washer (Item F) and tighten firmly.  
**CAUTION: DO NOT OVER TIGHTEN NUT OR BRACKET WILL BEND**
- 6) Attach SumoSpring (item A) **to the rear hole of the mounting bracket** using 3/8-16x3/4" bolt (item C) and torque to 25 ft. lbs. (see diagram)
- 7) Repeat steps three through five on the passenger's side of the vehicle.  
**NOTE: If more engagement is desired, the SumoSpring may be mounted to the bracket using the 1" spacer and 3/8-16x1-3/4 flange bolt.**
- 8) If rear wheels were removed you can now reinstall the rear wheels and torque wheel nuts to manufacturer's spec.
- 9) Jack up vehicle, remove safety jack stands.
- 10) Remove wheel blocks from the front wheels.
- 11) Fill out warranty card and send to SuperSprings. The warranty card is an attached document.

### **Important Notice.**

- 1) For easy installation please read instructions completely first and have all necessary tools available.
- 2) We recommend that this installation be done by a professional or persons with sound mechanical knowledge.
- 3) SumoSprings are designed to work with the original factory springs only. If they have been replaced with aftermarket springs then please consult with SuperSprings International at 866-898-0720.
- 4) These instructions are meant as a guide for the installation of SumoSprings. SuperSprings International assumes no liability for the actual installation process. Installers should apply common automotive safety practices when raising, lowering and working on vehicles.
- 5) SumoSprings are designed to enhance the vehicle's load carrying performance and road handling however it does not authorize (or recommend) loading beyond the manufacturer's GVWR specifications.
- 6) For technical support contact SuperSprings International at 866-898-0720.

***To prevent damage to the vehicle and to ensure safety, do not exceed the maximum load recommended by the vehicle's manufacturer (GVWR).***